

TECHNICAL CHARACTERISTICS

AHARXLETD

Hari XL

Armchair

The Hari XL chair, inspired by the world of textile looms, with a very industrial aesthetic combined with the delicacy of the threads to create a subtle and elegant chair.

DESIGNED BY ESTUDIOHAC



ondarreta

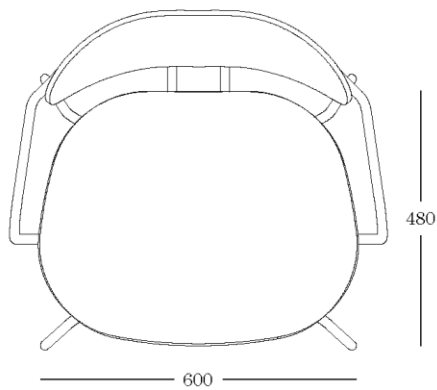
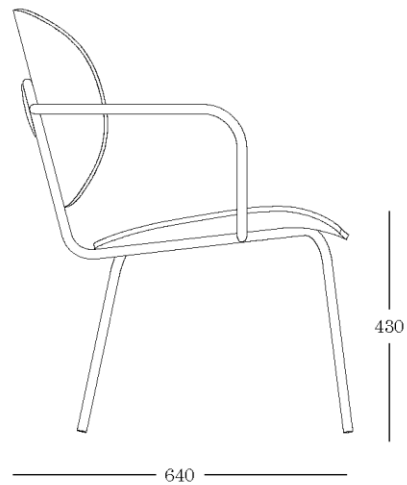
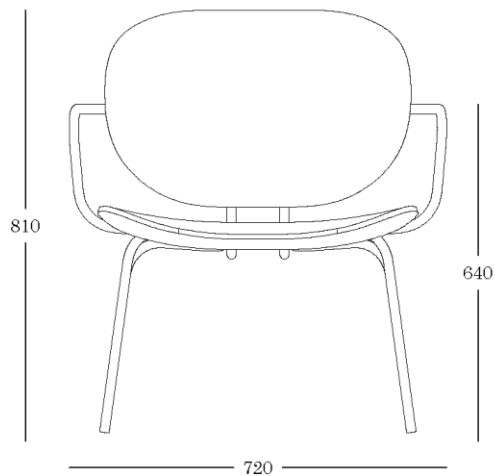

DIMENSIONS

72 cm x 64 cm x 81,5 cm x 43 cm
(28,4" x 25,2" x 32,1" x 17")
[width x depth x height x seat
height]

WEIGHT

10 kg (22,05 lb)

PACKAGING

One chair per box.
Box dimensions:
70 cm x 65 cm x 98,5 cm
(27,6" x 25,6" x 38,8")

CERTIFICATION

Product tested under the European
standard EN 16139:2013, category of
general use L2.

ACCESORIES

Felt glides

ORIGIN

100% Made in Europe

DESIGN

Estudi{h}ac



COMPONENTS

FRAME

Material

18 mm (0.7") side and 2 mm (0.08") thickness cold laminated E-220 quality (EN-10305 Normative) steel tube.

Tensile Strength > 310 N/mm² (44,960 psi);

Elastic Limit > 220 N/mm² (31,900 psi); Elongation > 23%

Finish

Colour epoxy

SEAT

Oak

Oak wood on Beech plywood, 10 mm (0.4") thick. It's made with especially treated sheets, glued, pressed and CNC machined.

Fabrics

8 mm (0.31") thick Beech plywood. It's made with especially treated sheets, glued, pressed and CNC machined.

Exclusive and unique upholstery system that allows the fabric a perfect adherence to the seat, maintaining the own chair's shape. Medium density polyether stuffing foam.

Finish

Stained oak and fabric.

BACK

Oak

Oak wood on Beech plywood, 10 mm (0.4") thick. It's made with especially treated sheets, glued, pressed and CNC machined.

Fabrics

8 mm (0.31") thick Beech plywood. It's made with especially treated sheets, glued, pressed and CNC machined.

Exclusive and unique upholstery system that allows the fabric a perfect adherence to the back, maintaining the own chair's shape. Medium density polyether stuffing foam.

Finish

Stained oak and fabric.

BUTTON

Material

Zamak material button; base metal of zinc and alloying

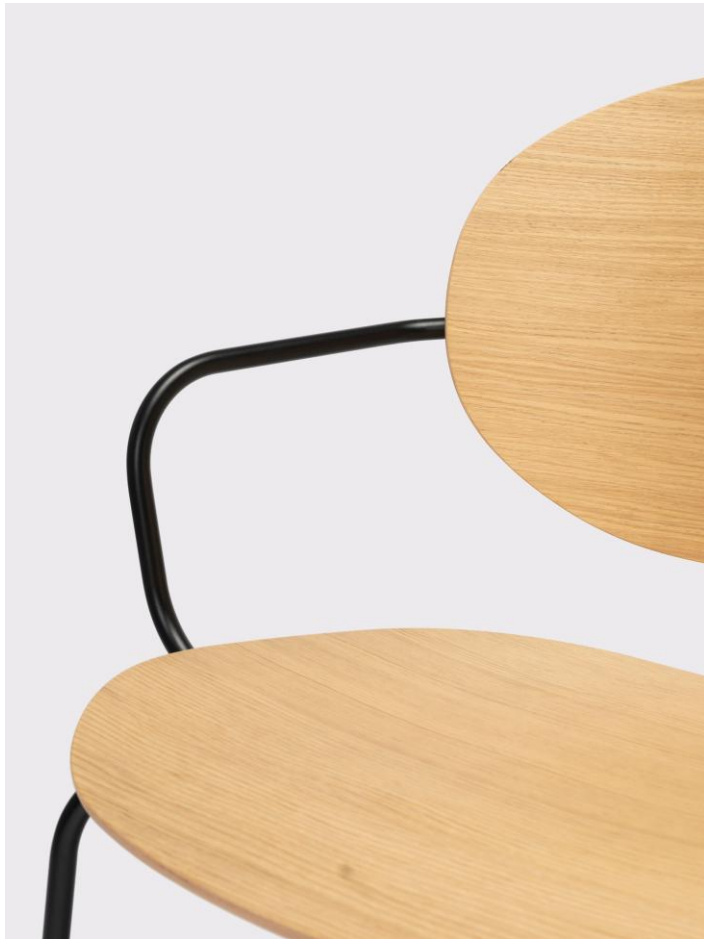

elements of aluminium, magnesium, and copper.

Complying with ISO 301-81, s/n UNE-EN-1774.

Finish

Colour epoxy (the same as the frame).

METAL FINISHES

EPOXYS

Powder covering formulated with polyester resins, with good both mechanical and chemical properties, outdoor maximum resistance and noxious compounds free. Electrostatic application and oven curated at 200°C (392°F).

Technical characteristics:

Thickness (ISO 2360): between 60 and 90 µm.

Adherence (ISO 2409): Grade: 0 (maximum adherence)

COM REQUIREMENTS

Full fabric (seat + back): 110 cm (43,4")