

TECHNICAL CHARACTERISTICS

BHARERBTB

Hari

Bench

Bench inspired by the world of textile looms, with a very industrial aesthetic combined with the delicacy of the threads to create a subtle and elegant seat.

DESIGNED BY ESTUDIOHAC



ondarreta

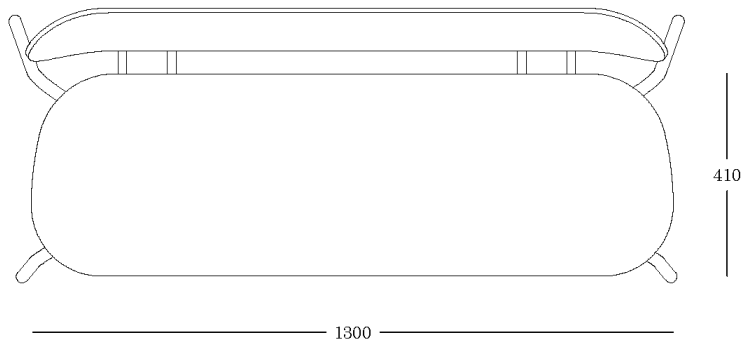
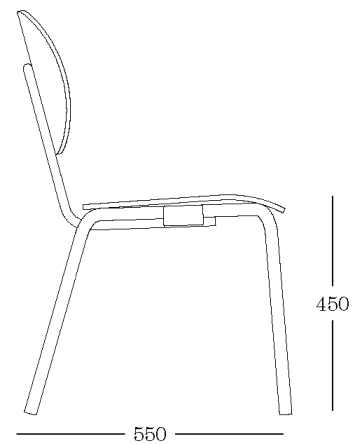
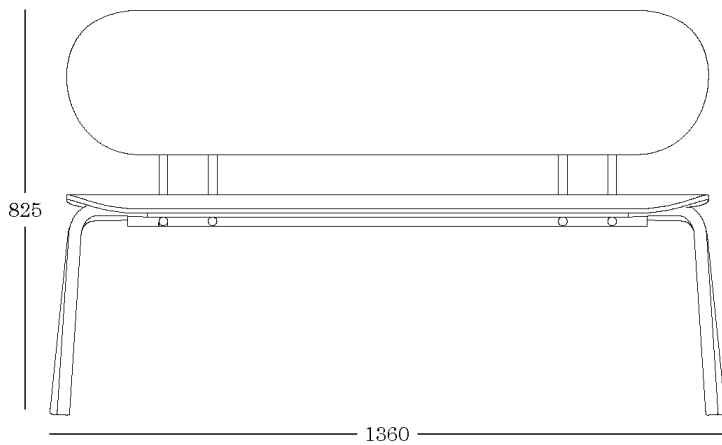

DIMENSIONS

136 cm x 55 cm x 82,5 cm x 45 cm
(53,5" x 21,6" x 32,5" x 17,7")
[width x depth x height x seat
height]

WEIGHT

18 kg (39,7 lb.)

PACKAGING

Box 1: 60 cm x 52 cm x 52 cm (23,6"
x 20,5" x 20,5")

Box 2: 134 cm x 60 cm x 46 cm
(52,7" x 26,6" x 18, 1")

ORIGIN

100% Made in Europe

DESIGN

estudi{h}ac



COMPONENTS

FRAME

Material

Beam made with precision tube of rectangular section of 80 mm x 40 mm and 2 mm thick in cold-rolled steel and structure composed of cylindrical tube of 25 mm diameter and 18 mm diameter of 2 mm thick precision in steel cold rolled.

Tube 18mm diameter and 80mm x 40mm: E-220 quality (according to Norm EN-10305); Tensile Strength > 310 N/mm² (44,960 psi); Elastic Limit > 220 N/mm² (31,900 psi); Elongation > 23%.

Tube 25mm diameter: E-420 quality (according to Norm EN-10305); Tensile Strength > 490 N/mm² (71,069 psi); Elastic Limit > 420 N/mm² (60,916 psi); Elongation > 12%.

Finish

Colour epoxy.

SEAT

Oak

Oak wood on beech plywood, 10 mm (0.4") thick. It's made with especially treated sheets, glued, pressed and CNC machined.

Fabrics

10 mm (0.4") thick beech plywood. It's made with especially treated sheets, glued, pressed and CNC machined.

Exclusive and unique upholstery system that allows the fabric a perfect adherence to the seat, maintaining the own chair's shape. Medium density polyether stuffing foam.

Finish

Stained oak or fabric.

BACK

Oak

Oak wood on beech plywood, 10 mm (0.4") thick. It's made with especially treated sheets, glued, pressed and CNC machined.

Fabrics

10 mm (0.4") thick Beech plywood. It's made with especially treated sheets, glued, pressed and CNC machined.

Exclusive and unique upholstery system that allows the fabric a perfect adherence to the back, maintaining the own chair's shape. Medium density polyether stuffing foam.





Finish

Stained oak or fabric.

BUTTON

Material

Zamak button: zinc-aluminium-copper alloy. Complying with ISO 301-81, s/n UNE-EN-1774.

Finish

Colour epoxy (the same as the frame).

METAL FINISHES

EPOXYS

Powder covering formulated with polyester resins, with good both mechanical and chemical properties, outdoor maximum resistance and noxious compounds free. Electrostatic application and oven curated at 200°C (392°F).

Technical characteristics:

Thickness (ISO 2360): between 60 and 90 µm.

Adherence (ISO 2409): Grade: 0 (maximum adherence)

WOOD FINISHES

STAIN

Pigmented enamel with a transparent stain coating. Reactive drying paints: excellent adherence between layers and better mechanical resistance.

Technical characteristics:

Satisfying UNE-EN 71-3 normative; Formaldehyde free compounds.

COM REQUIREMENTS

Seat fabric: 70 cm (27,6")

Full fabric (seat + back): 150 cm (59")

